

## Kegeerator Series

24" depth • 3 sizes



### FEATURES

Double tap stainless steel towers (3" diameter) and drip trays  
Keg couplers and hosing included  
Side knock out for exterior CO2 tanks  
Forced air tower cooling  
Left side mounted front venting compressor using R290 hydrocarbon refrigerant  
LED interior lighting  
Adjustable epoxy coated 90 lb. capacity shelves  
Dixell digital controller with automatic defrost programming  
Self-evaporating water tray – no drain needed  
ETL Listed and conforms to NSF Std. 7  
Standard 15 amp plug



### WARRANTY



Parts & Labor

+



Compressor  
*part only*

Model	Doors	HP	Amps	Volume	½ Keg Capacity	Width	Depth	Height
IM48NDD2	2	1/5	2.88	11.8 Cu. Ft	2	Ext: 48.8" Int: 36.25"	Ext: 24.4" Int: 18.5"	Ext: 35.6" Int: 28.9"
IM60NDD2	2	1/5	2.88	15.8 Cu. Ft	2	Ext: 60.75" Int: 48.25"	Ext: 24.4" Int: 18.5"	Ext: 35.6" Int: 28.9"
IM72NDD3	3	1/4	3.96	19.6 Cu. Ft.	3	Ext: 72.75" Int: 60.1"	Ext: 24.4" Int: 18.5"	Ext: 35.6" Int: 28.9"

IM48NDD2

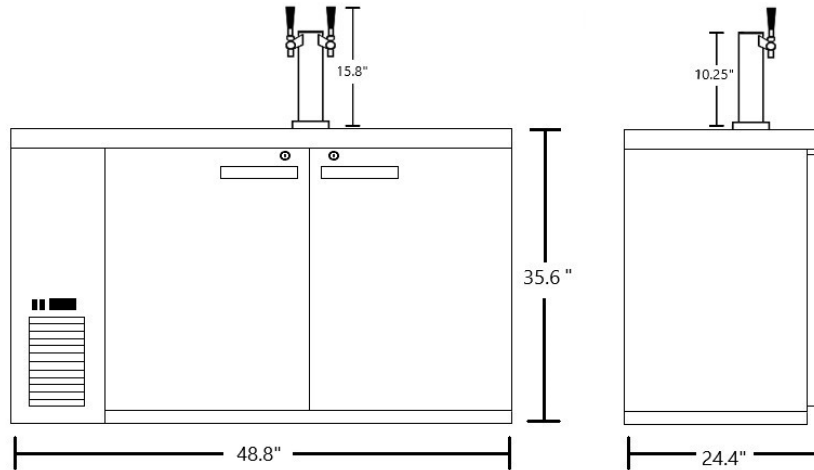

**Keg layouts**

1/2 kegs must be loaded through right side door

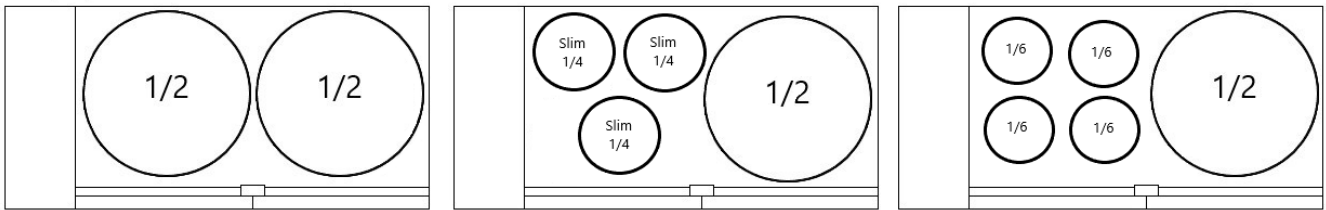

IM60NDD2

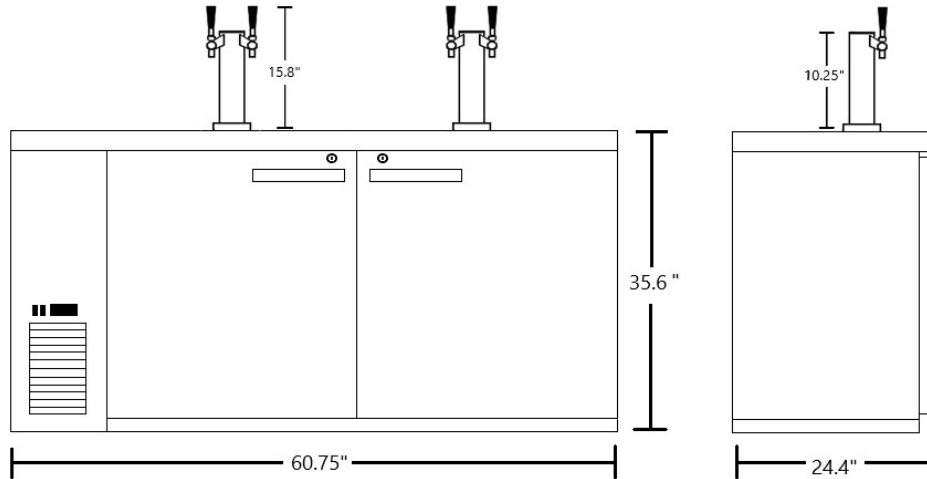

**Keg layouts**

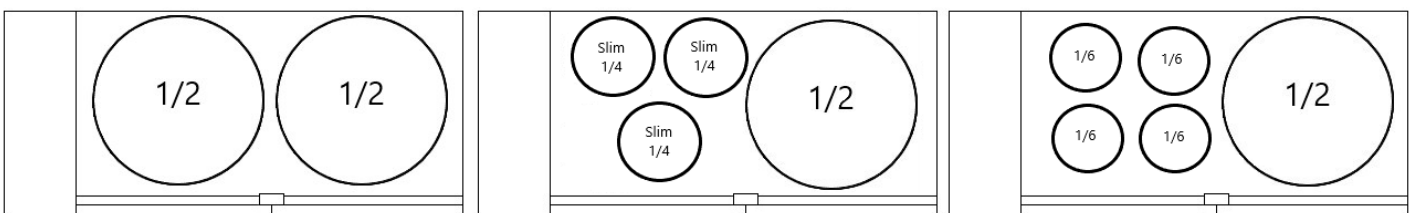

IM72NDD3

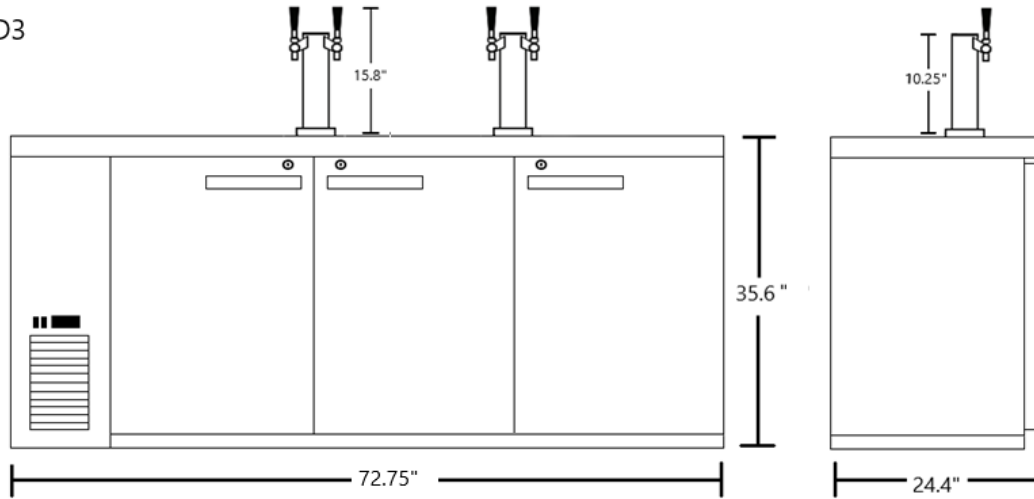

**Keg layouts**

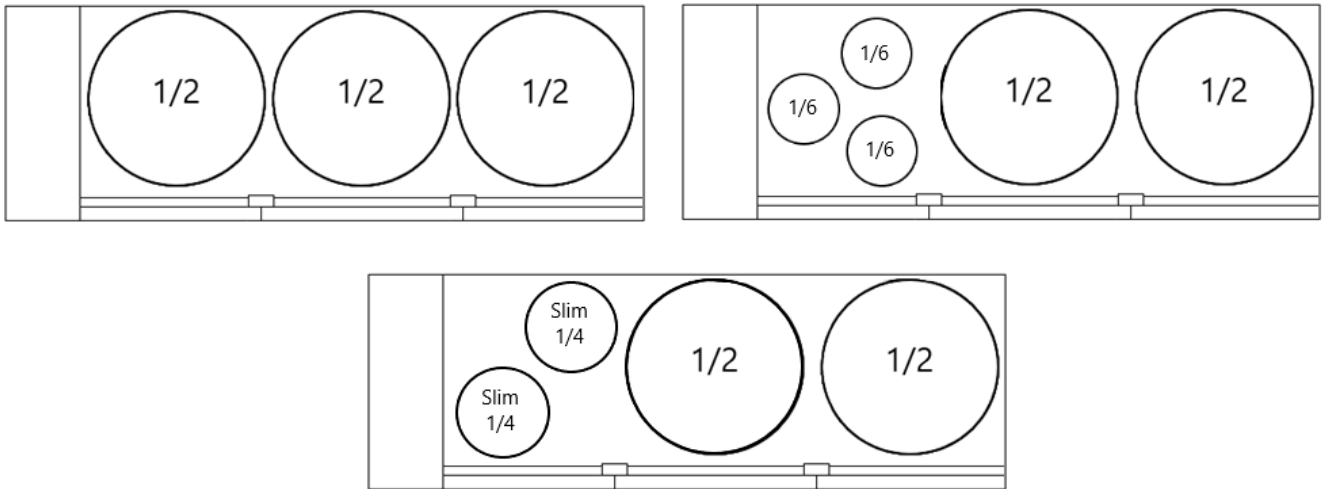

\* Keg layouts are suggested. Air circulation must be maintained around each keg for proper cooling. Allow 24 hours for kegs to reach serving temperature.